

Thank you for purchasing a HomeRoots product. This product has been designed for easy assembly and is constructed for durability. Please take this time to read and follow the assembly instruction carefully. If a part or hardware is missing or you have any difficulties in assembling this product, please contact us 862-203-8249 or [cs@homeroots.co](mailto:cs@homeroots.co)

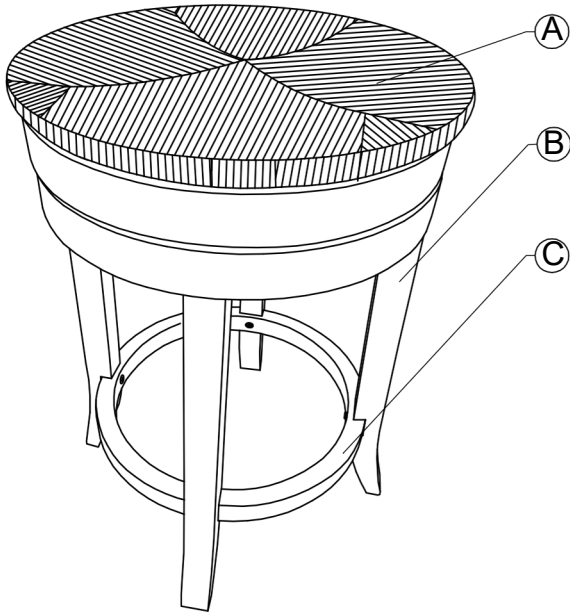



**ASSEMBLY INSTRUCTION**  
ITEM#1924 /1930



**PARTS CHECK LIST**

CODE	COMPONENTS	Q'TY
(A)	SEAT	x01
(B)	LEGS	x04
(C)	FOOT RING	x01

**FITTINGS CHECK LIST**

CODE	DESCRIPTION	Q'TY
(D)	 JCBC M6 x 35mm	x08
(E)	 JCBC M6 x 40mm	x04
(F)	 SPRING WASHER M6	x12
(G)	 FLAT WASHER M6	x08
(H)	 ALLEN KEY M4	x01

1. Assemble legs (B) to the seat (A) with JCBC (D), spring washer (F) and flat washer (G).  
Do not tighten all the way until step 2 is completed.

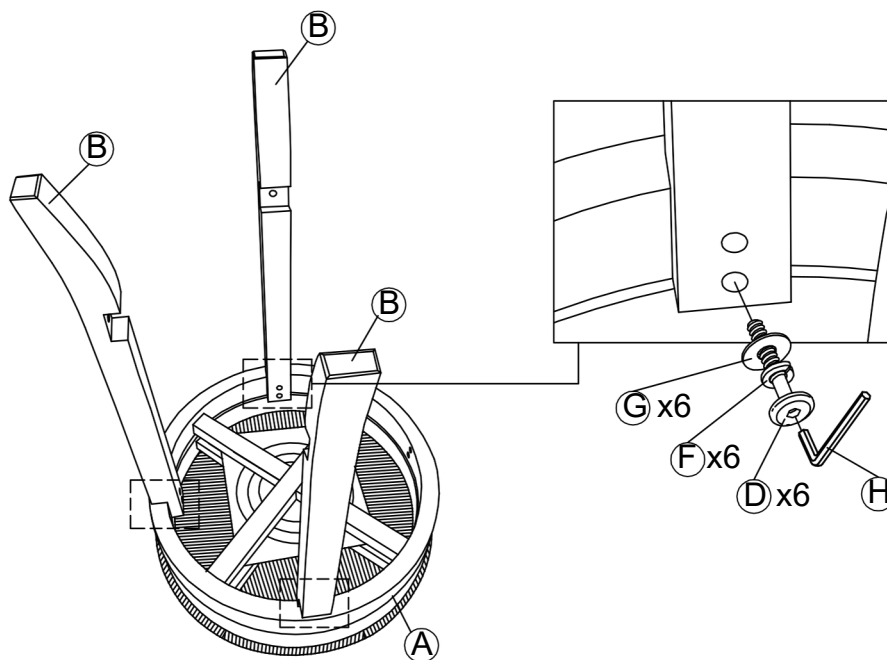

2.

STEP 2 - Tighten the foot ring (C) to leg (B) with JCBC (E) and spring washer (F).

STEP 2.1 - Assemble legs (B) to the seat (A) with JCBC (D), spring washer (F) and flat washer (G).

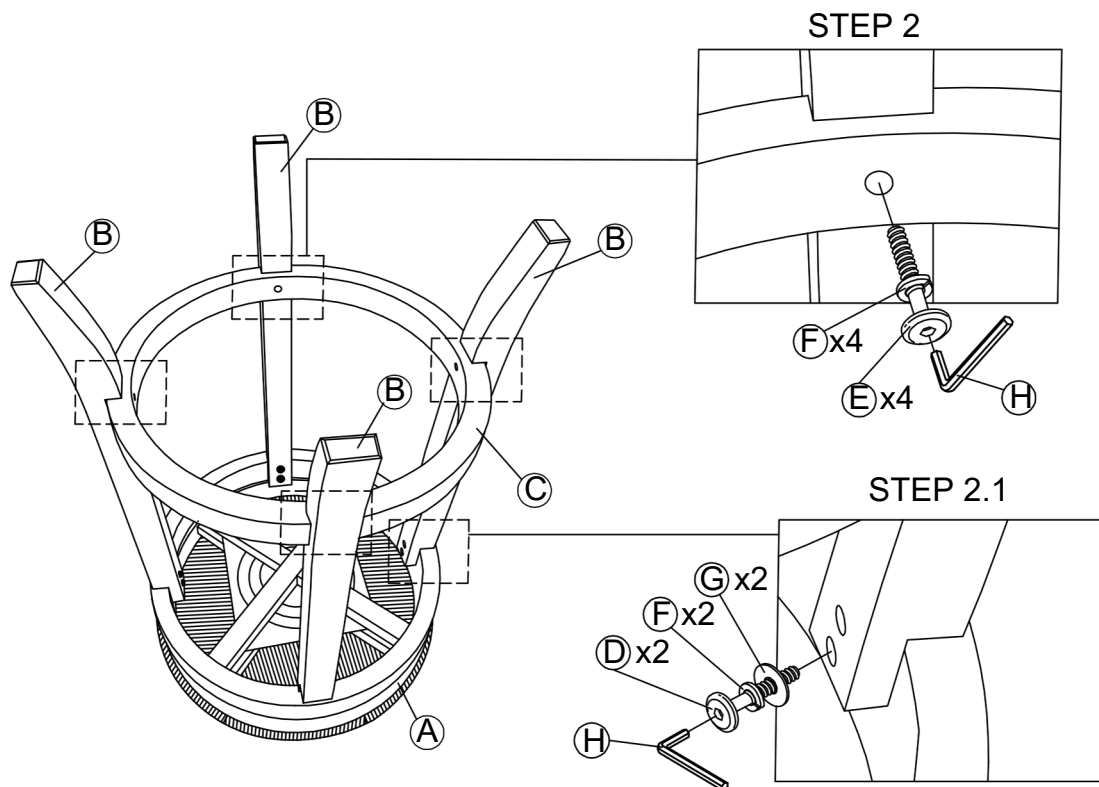

3.

Please make sure all screws are tightened 100%.

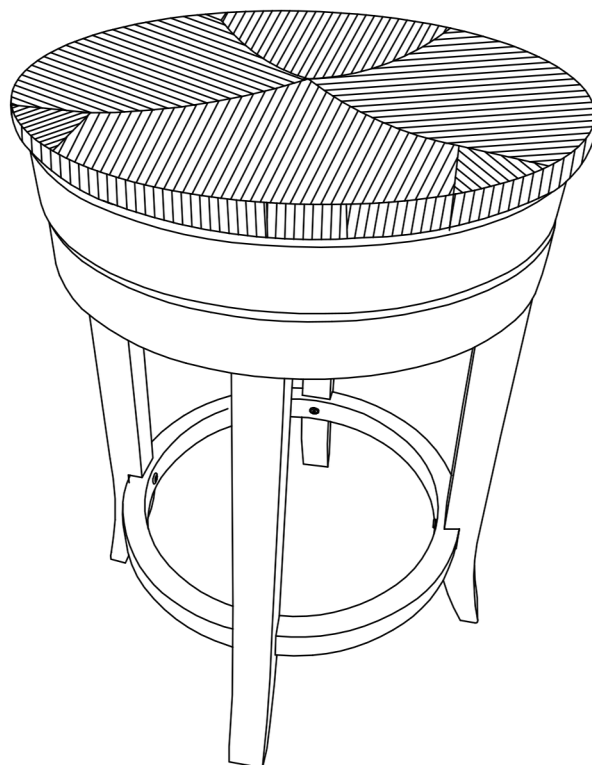

ASSEMBLY  
COMPLETED!!!

